



elan
audio

2 STEEL COURT SOUTH GUILDFORD WA 6055
PHONE (08) 9277 3500 FAX (08) 9478 2266
email sales@elan.com.au
web www.elan.com.au

RMR-01

Professional AM-FM Off-Air Receiver System



The RMR-01 AM-FM Receiver is the complete Off-Air Monitor systems solution for Radio Broadcast Stations, whether they are Government, Commercial, Community or Narrowcast.

The RMR-01 is Rack Mounted, requiring 2 RU of Rack Space and is based on the Philips high performance TEA 6845H Car Radio front end IC used in top of the range European Car Radios.

FEATURES

- High Impedance Antenna Input, allowing several RMR-01 receivers to feed from one antenna
- Stable Crystal Locked, Microprocessor Controlled Tuning
- MW AM Band 522 KHz, extended to 1728 KHz for Narrowcast, Tuned in 9 KHz Steps
- Standard FM Band 87.5 MHz to 108.1 MHz, Tuned in 100 KHz Steps
- Band Switching, Tuning and Calibration protected against accidental operation
- AM or FM Mode is displayed by LED's, Tuned Frequency on 4 x 7 Segment LED Display
- Unbalanced Left and Right Outputs, suitable to feed Sound Card in PC Based Logger
- Built in Distribution Amplifiers giving 10 Left, 10 Right and 5 Mono +4 dBu Balanced Outputs
- 3.5 V PP Composite Stereo Output on BNC Connector to feed external equipment
- Calibrated Carrier Level Display indicating changes to Carrier Level
- Separate Left and Right PPM Audio Level Indicators in 3 dB Steps including Overload LED
- Mono Confidence Loudspeaker with Volume Control, and Stereo Headphone Outlet
- Program Fail, Carrier Fail and Common Alarm Outputs on Floating Relay Contacts
- Common Alarm Defeat Switch, and additional Open Collector Alarm Status Outputs
- Internal DIP Switch Selectable Program Fail Level and Timeout Delay
- Operation from Standard 220 to 250 V AC Mains

APPLICATIONS

- Off-Air Monitor Receiver System in AM or FM Radio Broadcast Stations
- Demodulating Monitor Receiver on Broadcast Transmission Sites
- Re-Broadcast Receiver
- General High Quality AM-FM Hi-Fi Tuner

PLEASE NOTE

Although the RMR-01 will accept relatively high RF Levels, and is capable of very good Audio Performance making it suitable for use on Transmitter Sites as a Monitor and Alarm Receiver.

It is NOT a Precision Modulation Monitor suitable for Proof of Performance Measurements.

TECHNICAL SPECIFICATIONS

Antenna Input BNC Socket, High Impedance

AM Performance

Tuning Steps 9 KHz
Frequency Coverage 522 to 1728 KHz

AF Frequency Response WRT 400 Hz +0 –1 dB 30 Hz to 2.8 KHz
-2 dB 3.5 KHz
-3 dB 3.9 KHz
-6 dB 4.4 KHz
-9 dB 4.7 KHz
-12 dB 4.9 KHz

Distortion WRT 400 Hz 40% Modulation 0.41%
90% Modulation 0.68%

Signal to Noise Ratio WRT 100% Mod RF Level 10 uV 30 dB
RF Level 100 uV 48 dB
RF Level 1 mV 58 dB
RF Level 10 mV 60 dB
RF Level 100 mV 60 dB

AGC Performance RF Level 10 uV to 100 mV
AF Level Variation 0.1 dB

Max RF Input Level 500 mV

FM Performance

Tuning Steps 100 KHz
Frequency Coverage 87.5 to 108.1 MHz
AF Frequency Response WRT 50 u Sec Pre Emphasis
Better Than + and – 1 dB 20 Hz to 15 KHz

Distortion 400 Hz 40% Modulation 0.1%
400 Hz 100% Modulation 0.15%

Channel Separation Typical 45 dB
Signal to Noise Ratio Typical 71 dB
Max RF Input Level 500 mV
Composite Output Level 3.5 V PP at 400 Hz 100 % Modulation

Audio Outputs

Unbalanced 2 x RCA, 300 mV Stereo
Balanced 1 x D 25 Male 10 x + 4 dBu Left Channel
1 x D 25 Male 10 x + 4 dBu Right Channel
1 x D 25 Male 5 x +4 dBu Mono

Alarm Outputs

On Mono Connector
3 x Floating Relay Contacts
6 x Open Collector Alarm Outputs

Physical

Power 220-260V AC 20 VA

Size W 482.6 mm x H 88.9 mm x D 270 mm

Size packed in Carton W 520 mm x H 130 mm x D 310 mm

Weight Packed in Carton 5 KG

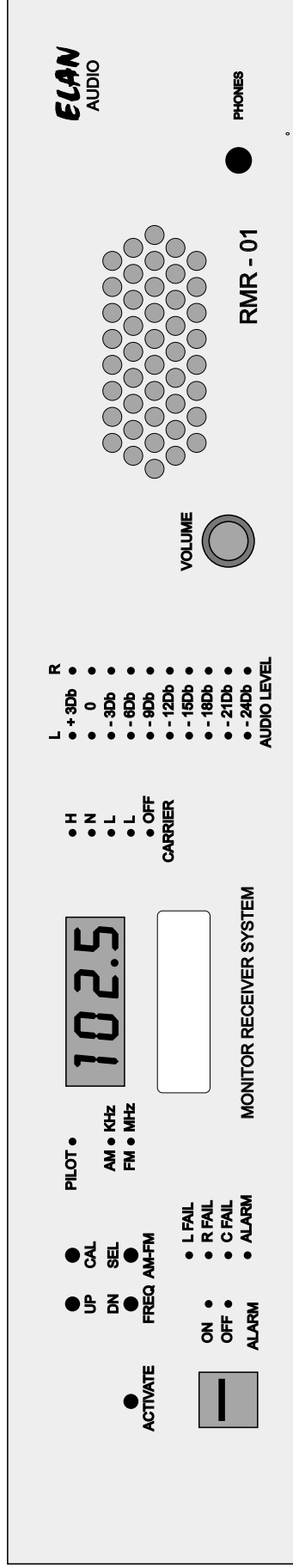

RMR-01 FRONT ELEVATION



RMR-01 REAR ELEVATION

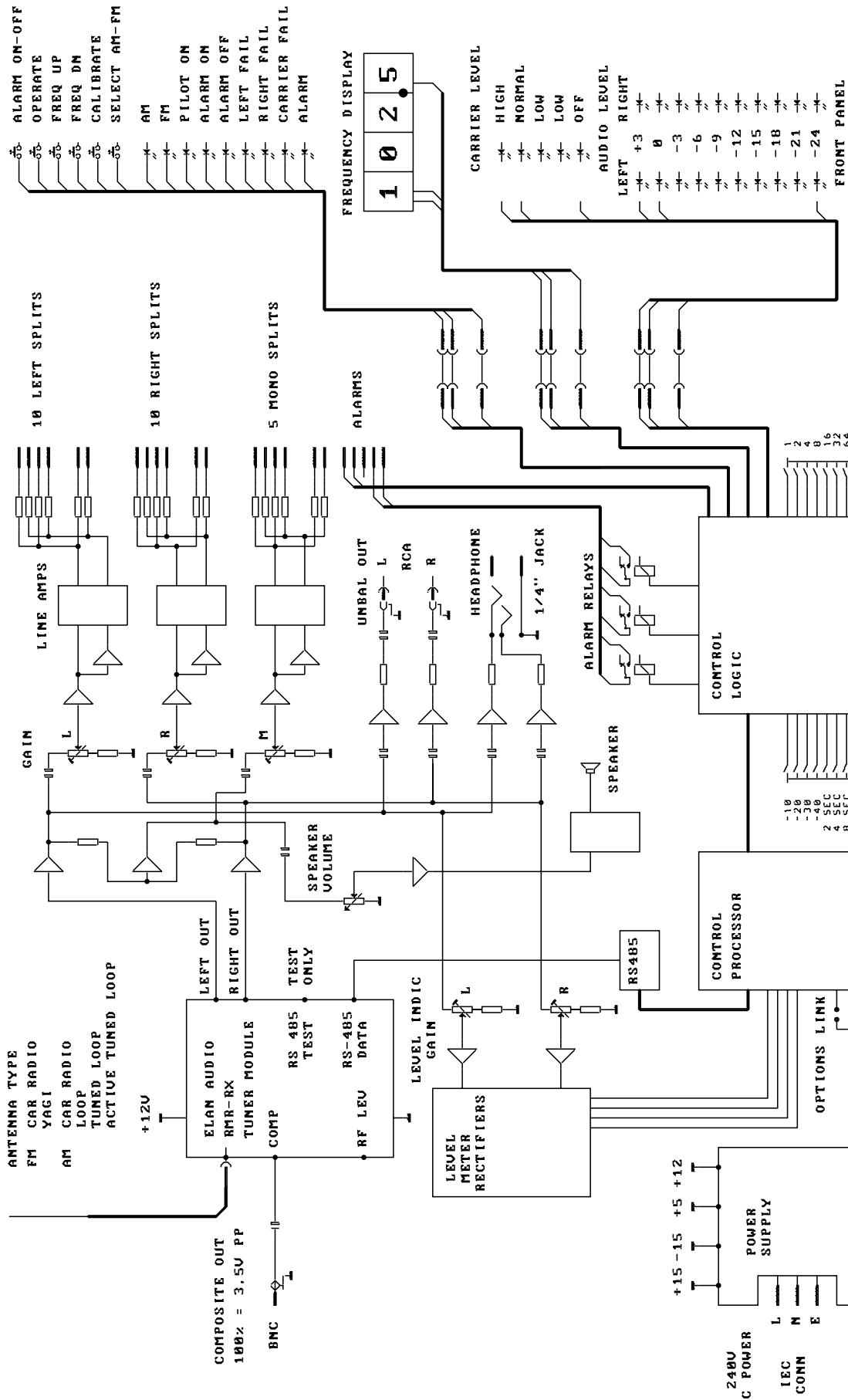

ELAN AUDIO AUSTRALIA

Title		BLOCK DIAGRAM RMR-01
Size		AM-FM MONITOR RECEIVER
Revision	Number	RMR01BK
43	Date:	9-00T 2802
File:	RMR01BK/1	Sheet of
	Drawn By:	

RMR-01 AM-FM BROADCAST MONITOR RECEIVER

FAIL LEVEL SENSITIVITY AND RECOVERY TIME

OPTION LINKS

FAIL TIMEOUT

OPTION LINKS

- 1
- 2
- 4
- 8
- 16
- 24
- 128

