

ELAN Audio

Promotional Information

"HAWK 8" Broadcast "On-Air" Mixing Consollette



Manufactured in Western Australia

By Elan Audio 2 Steel Court South Guildford W.A.
Phone (08) 9277 3500 Fax (08) 9478 2266
www.elan.com.au email poulkirk@elan.com.au
ABN 90 093 605 249

hawk8.jpg (831x511x16M jpeg)



590 mm

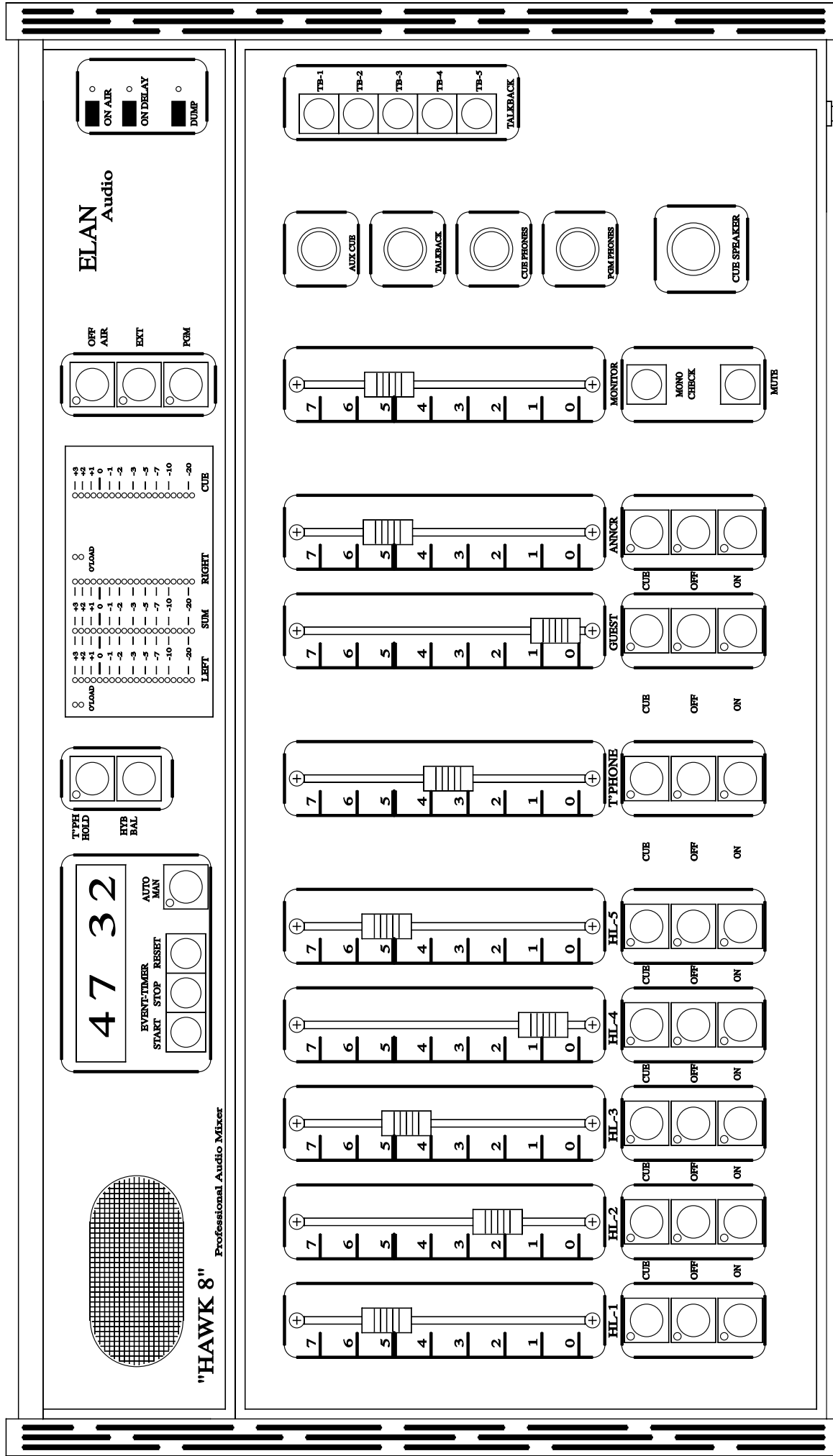

PHYSICAL DIMENSIONS
 WIDTH: 590 mm
 DEPTH: 360 mm
 HEIGHT: 145 mm

ANNOUNCERS
 HEADPHONE
 SOCKET

ELAN AUDIO "HAWK" ON AIR MIXER

"HAWK-8" Technical description.

The "HAWK-8" is a Professional Broadcast Audio Mixing Consollette, designed for "On-Air", News and General Broadcast Production.

It is provided with all the features normally expected on a Professional Broadcast Mixer, such as "On-Air", Delay and Delay Dump switching, Microphone activated Loudspeaker Muting, Remote Machine Control facilities, Telephone Mix- output, Talkback facilities and many more.

The "HAWK-8" is extremely compact and designed for mounting on top of the Operators or Announcers desk, requiring only a few cable access holes making installation quick and simple.

All connections in and out from the "HAWK-8" are via sturdy easily accessed screw terminals.

The Mixer is constructed using a minimum number of different Printed Circuit Boards, which are all easily removable using basic tools, with all connections between Printed Circuit Boards using Plugs and Sockets.

Programmed Microprocessors are used freely in the Control Circuitry with the different processors listed in a following section.

The attached Overall Block Diagram, show the signal flow through the mixer and the general circuit arrangement.

The individual Printed Circuit Boards in the "HAWK-8" are described in the following text.

INPUT BOARD, Type HAWK-01.

This board is provided with the 8 sets of input circuitry on the "HAWK-8" Mixer.

High Level inputs 1 to 5 are identical having Balanced Stereo inputs.

First OP-Amp is connected in the differential mode presenting an input impedance of about 50 K Ohms to the programme source, and have a gain of 0.5.

Any DC on the input, is isolated by a Bipolar Electrolytic, and fed to the second stage OP-Amp via a gentle HF roll off network consisting of a 1 K Ohm series resistor and 1000 PF shunt capacitor.

Gain is controlled in the feedback circuit of the second stage, and is arranged to accommodate nominal input levels ranging from 300 mV from Hi-Fi type source equipment, to about +10 dBu from normal balanced Broadcast Equipment.

A generous overload margin above this level is allowed for in the design.

The Telephone Input, is Monophonic and otherwise identical to the Stereo High Level inputs.

The Microphone inputs, Guest and Announcer is transformerless and balanced and based on the SSM-2017 Low Noise Microphone Pre-Amplifier IC.

Provision is made for + 15V DC Phantom Powering of Condenser Microphones with the Phantom Power DC being isolated from the Pre-Amp by 100 MFD input coupling Capacitors.

Protection for the SSM-2017 is provided by 22 Ohm series resistors and shunt Diodes.

Input impedance of the Microphone channels is about 1.8 K Ohms, and will suit most types of Balanced Microphones.

3 stages of gain control for the SSM-2017 is provided using a movable shunt, giving nominal input levels of -70 dBV, -60 dBV, and -50 dBV.

The -70 dBV setting, High Gain is suitable for low output Microphones such as Ribbon type or for distant Microphone pick up, the -60 dBV setting is suitable for normal Dynamic Microphones at a normal speaking distance, with the -50 dBV setting suitable for High Output Microphones such as certain Electret types.

Output from the SSM-2017 Pre Amplifier stage is fed to a final buffer stage via a Bipolar Electrolytic.

The final stage gain is controlled by a Pre-set potentiometer connected in the feedback circuit, and fed to the output of the HAWK-01 Board.

All outputs are isolated by Bi-polar Electrolytics, and have the same nominal level of 0 dBu.

Connections between the HAWK-01 Input Board, and the HAWK-02 Mixer Board, is via two IDC Ribbon cables, one 10 wire and one 16 wire.

Mixing Board, HAWK-02.

All Programme Mixing, Switching and Gain Summing takes place on this Board.

Input signals are fed directly to the High end of the Faders with Programme and Cue switching taking place in SSM-2402 and SSM-2404 switching ICs.

Mixing resistors are provided downstream of the switching ICs, with the Programme audio treated as individual Left and Right channels, and the Cue channel being the Mono sum of Left and Right.

Summing is done in the inverting mode, meaning that summed output levels are constant regardless of Fader position and Channel switch states.

The five High Level channels all have identical circuits, with the Telephone channel and the two Microphone differing slightly, please see the overall block diagram for principle details.

Channel On-Off and Cue control is by Microchip PIC Microprocessors which control Channel Audio switching, Channel status LEDs, Timer Start, Machine Control and Loudspeaker Muting.

The following Audio outputs, Mic Cleanfeed, Telephone Feed, Record Feed, Cue Bus, Programme Left and Programme Right, all operate on a nominal output level of 0 dBu, and appear on 20 way IDC connector P6, which connects via a 20 way ribbon cable to the Output Board, HAWK-03.

The Cue Change, and Loudspeaker Mute Bus also appear on this connector, and is Active High.

Other control connections appear on P5, 14 way ribbon to the Remote Control Board, HAWK-08, and P4, 10 way ribbon carry connections to the Timer board, HAWK-05.

Output Board, HAWK-03.

Audio outputs from the HAWK-02 Board, feed the various Line Amplifier circuit on the HAWK-03 Board.

These circuits are substantially identical, and consists of an OP-Amp connected as a Buffer Amplifier with a Pre-set potentiometer connected in series with the inverting input for gain trim adjustments which feeds an SSM- 2142 Balanced Output Line Amplifier.

The SSM-2142 is protected by 22 Ohm resistors in each output leg, giving an output impedance of about 50 Ohms, the gain control Pre-set potentiometer allows adjustment of the Line Output levels between -2 dBu and +10 dBu.

5 Talkback Relays, controlled from switches on the Monitor Board, HAWK-04, channel Microphone Cleanfeed signal to the Talkback outputs.

Monitor Inputs and Monitor switching are provided on the HAWK-03 Board, with the inputs balanced via OP-Amps connected in the Differential mode.

Programme Monitoring is derived directly from the Programme Output circuitry, with Off-Air and Extension monitoring being provided with the Differential Balanced input stages.

Talkback in, and Auxilary Cue inputs are also Differential Balanced.

A small Audio Power Amplifier, is provided to feed the Built-in Cue Loudspeaker.

The Guest Headphones are Monophonic, and are derived and summed from the main Programme Outputs.

Monitor Board, HAWK-04.

The Monitor Board have the following circuitry.

Mono Check switch, shorting Left and Right monitor channels together to check mono compatibility, Monitor Fader, Monitor Mute switch, and a Buffer Amplifier, feeding the Monitor Line Amplifier located on the HAWK-03 Board.

Announcers Headphone level control, and Split Cue switching, allowing Cue signal into one side of the Announcers Headphones when the Cue Bus is active, and the Announcers Headphone Amplifier.

Additional facilities are the 5 Talkback control switches operating Relays on the HAWK-03 Board, a manual Mute switch, Talkback and Auxilary Cue level controls, Cue Loudspeaker and Cue Headphone Level controls.

All connections to the HAWK-04 Board are via Ribbon cable and headers from the HAWK-03 Board.

Timer Board, HAWK-05.

The Timer Board is based on a Microchip PIC Microprocessor, and have a 4 digit time display, and two Telephone Control switches which connect to the HAWK-02 Board via a 10 way ribbon cable.

The Timer may be controlled Manually by the Start, Stop and Reset buttons on the front, and Automatically by signals from the Hawk-02 Board.

A toggle action switch is provided on the Timer Board which activates the Auto-start input of the Timer Board when the LED indicator is illuminated.

The two Telephone control switches have the following functions.

Telephone Hold, pressing this switch, will take the telephone call, and connect it to the Hybrid unit, and feed Programme back to the subscriber.

The line can then be taken to Cue, where the Announcer can converse with the caller, and conduct an interview with the caller while in Cue.

The call can be transferred to On, to go to air, or back to Hold.

Pressing the Channel Off switch, will disconnect the call.

Pressing the Hybrid Balance switch, will send a momentary closure to ground to re-balance the Hybrid

VU Display Support Board, HAWK-06.

This Board is a support and mounting board for the Audio Level Indicator LEDs, Audio Indicator Drivers and the Monitor Control Processor and switches.

It connects to the HAWK-03 Output Board via a 20 way Ribbon Cable.

The Monitor Control Processor, is a Microchip PIC device which is programmed to switch monitoring to the Off-Air condition on power up.

Output to the Monitor Switches on the HAWK-03 Board is Active High.

VU Display Driver Board, HAWK-07.

This Board, plug onto the back of the HAWK-06 Board, and contain the VU Display Driver circuitry for one Meter Display.

Four identical boards are fitted to the HAWK-8 Mixer.

Input is Differential Balanced, and feed a full wave active rectifier circuit via a Bipolar Electrolytic to remove any DC on the input.

Meter Alignment sensitivity is adjustable from -2dBu to +10 dBu via VR1, and scaling is adjustable via VR2.

One side of the active rectifier is fed from a Phase Inverter with the output of the rectifier charging a Capacitor C2 via R9.

Discharge of C2 is via R9 and R8.

Voltage across C2 is amplified by IC2 and fed to the Display Driver ICs 3 and 4 LM3914.

Transistor Q3 is connected into the feedback path of IC2, and is biased to give a VU Meter scaling characteristic to the LED Display.

An overload flasher based on two voltage comparators, IC5 A and B LM393 is provided which will flash the overload LED whenever a certain peak level is exceeded.

Overload Flash point is adjustable via VR3, and is usually set to occur 10 dB above Alignment Level.

Remote Control Board, HAWK-08.

This Board contains the Machine Start-Stop remote control circuitry and Relays, Logger Start Relay, On-Air Light Relay, Telephone Hybrid Control Relays and the Cough Mute inputs.

The Machine Control circuitry is based on two PIC Microprocessors with Remote control facilities available from High Level inputs, 2, 3, 4 and 5.

The Logger Start, On Air Light and Telephone Control Relays, and the Cough Mute inputs are direct acting functions which are driven from the HAWK-02 Board.

Power Supply Unit, PSU-01 and Power Supply Reticulation.

Power supply entry to the "HAWK-8" Mixer is via Screw Terminals mounted on the HAWK-03 Board, and reticulated to the other Boards in the mixer via Plug Removable cables.

Power from the supply is Regulated + 15V DC, - 15V DC for the Audio Electronics, and + 12V DC for Control circuits and Relays.

+ 5V Regulators are fitted on some of the other Boards in the Mixer to provide the +5 V required for the Microchip PIC Microprocessors and other logic circuitry.

The PSU-01 itself is mounted in a small free standing metal case, and is of straightforward design.

Regulators provide the three required voltages, with protection circuitry and Relays switching all power off from the output, in case of Fuse and Regulator failure on one supply leg.

"HAWK-8" Technical Specifications.

Line Inputs, Differential Balanced Z in appx 50 K Ohms.
Mic Inputs, Differential Balanced Z in Greater than 1K Ohm.
Line Outputs, Differential Balanced Z out appx 50 Ohms.

Line Input Level, adjustable from 300 mV to + 10 dBu.
Output and Level Display Alignment Level, adjustable 0 dBu, +4 dBu and +8 dBu.

Output Crash Level + 24 dBm into 600 Ohms or greater.

High Level Channel in, Programme Line out.

Mixer gain Unity, Input level +16 dBu, Output Level +16 dBm, Load 600 Ohms.

		Actual measurements.
Frequency Response, +0 -0.2 dB.	20Hz to 20 KHz.	(-1 dB 9 Hz to 80 KHz)
Harmonic Distortion, 100 Hz	0.02%	(0.015%)
1000 Hz	0.02%	(0.015%)
10 KHz	0.04%	(0.03%)
S/N Ratio 20 Hz to 20 KHz	88 dB.	(93 dB)
Crosstalk	65 dB or better	(86 dB at 1 KHz)

Microphone Channel in, Programme Line out.

Mixer Gain 68 dB, Input Level -52 dBV, output level +16 dBm, Load 600 Ohms.

		Actual measurements.
Frequency Response, +0 -0.2 dB	20Hz to 20 KHz	(-1 dB 11 Hz to 100 KHz)
Harmonic Distortion, 100 Hz	0.05%	(0.045%)
1000 Hz	0.025%	(0.02%)
10 KHz	0.06%	(0.05%)
S/N Ratio 20 Hz to 20 KHz	74 dB	(76 dB)

EIN varies with Microphone Pre-Amp setting, normally expect -120 dBV in Low Gain setting, -126 dBV in Mid Gain setting and -129 dBV in High Gain setting.

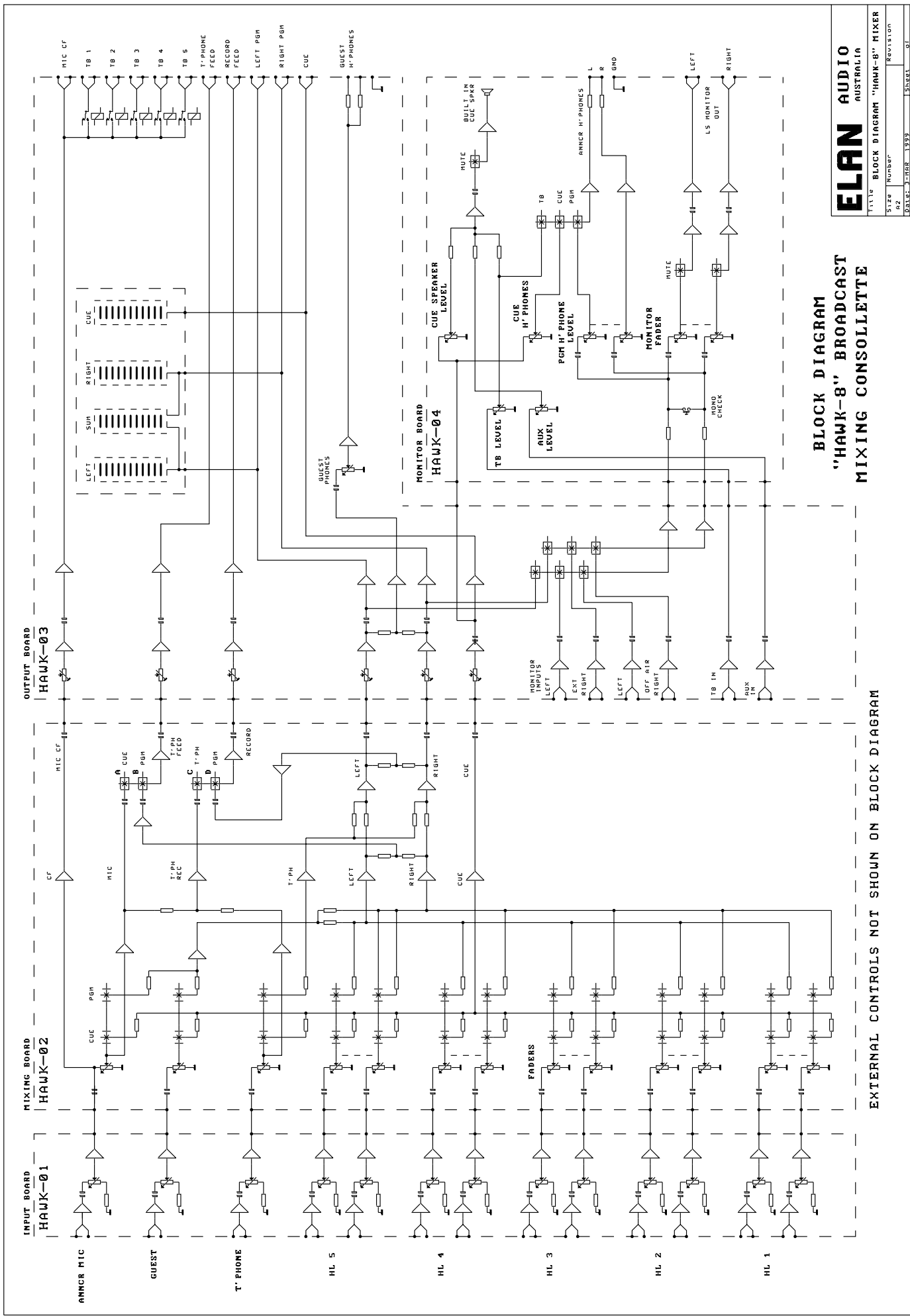

**BLOCK DIAGRAM
"HAWK-8" BROADCAST
MIXING CONSOLLETTE**

ELAN AUDIO AUSTRALIA	
TITLE	BLOCK DIAGRAM "HAWK-8" MIXER
SIZE	Number
REV	Revision
DATE	3/95
DRAWN BY	ST
CHECKED BY	ST

EXTERNAL CONTROLS NOT SHOWN ON BLOCK DIAGRAM

"HAWK-8" REMOTE CONTROL BOARD TYPE HAWK-08



HL-2 | HL-3 | HL-4 | HL-5 | LOG | ON-AIR | T' PH | COUGH | PWR | MUTE

"HAWK-8" INPUT BOARD TYPE HAWK-01

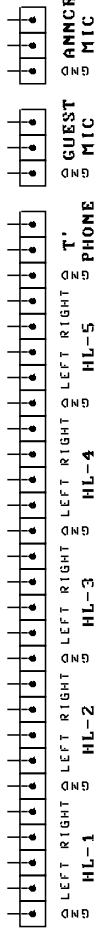

HL-1 | HL-2 | HL-3 | HL-4 | HL-5 | T' PHONE | GUEST | ANNCR | MIC

"HAWK-8" OUTPUT BOARD TYPE HAWK-03

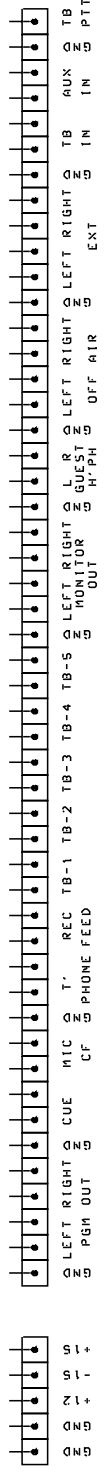

SUPPLY | IN | OUT | PGM | OUT | CUE | MIC | T' PH | REC | FEED | FEED | OUT | OUT | TALKBACK | OUT | MONITOR | OUT | GUEST | H'PH | MONITOR | OFF AIR | EXT | AIR | MONITOR | LEFT | RIGHT | TB | EXT | LEFT | RIGHT | TB | AUX | TB | IN | IN | IN | IN | PTT

**"HAWK-8"
ON-AIR MIXER
INPUT AND OUTPUT
TERMINAL PLACEMENT**

ELAN AUDIO
AUSTRALIA

Title "HAWK-8" TERMINALS	
Size A3	Number HAWK08TER
Page: 1 of 1	Sheet: 01
File: HAWK08TER1	Drawn: Bst